



PARTS MANUAL

EMP 285ic 1ph & EMP 285ic 3ph



Valid for: serial nos. 745-xxx-xxxx, 747-xxx-xxxx

Rights reserved to alter specifications without notice.

PART # 0463 619 001

© ESAB AB 2018

Ordering number	Product	Notes
0558102554	EMP 285ic 1ph	Bobbin Ø4-12 in. (100-300 mm) CSA, bayonet
0558102556	EMP 285ic 3ph	Bobbin Ø4-12 in. (100-300 mm) CSA, bayonet

Spare parts are to be ordered through the nearest ESAB agency. Kindly indicate type of unit, serial number, denominations and ordering numbers according to the spare parts list.

Maintenance and repair work should be performed by an experienced person, and electrical work only by a trained electrician. Use only recommended spare parts.

SECTION TABLE OF CONTENTS

Paragraph		Page
SECTION 1 HOUSING PARTS		
1.1	HOUSING PARTS.....	1-1
SECTION 2 CONNECTION PARTS		
2.1	CONNECTION PARTS	2-1
SECTION 3 USER-INTERFACE PARTS		
3.1	USER-INTERFACE PARTS.....	3-3
SECTION 4 CONTROL/POWER MODULE PARTS		
4.1	CONTROL/POWER MODULE PARTS FOR EMP 285IC 1PH.....	... 4-1
4.2	CONTROL/POWER MODULE PARTS FOR EMP 285IC 3PH.....	... 4-3
SECTION 5 WIRE-FEED ASSEMBLY PARTS		
5.1	WIRE-FEED ASSEMBLY PARTS.....	5-5

SECTION LIST OF FIGURES

Figure	Page
Figure 1-1. Housing	1-2
Figure 2-1. Connections	2-2
Figure 3-1. User-Interface	3-4
Figure 4-1. Power-Side Module Parts, EMP 285ic 1ph	4-2
Figure 4-2. Power-Side Module Parts, EMP 285ic 3ph	4-4
Figure 5-1. Wire-Feed Assembly	5-7

SECTION LIST OF TABLES

Table	Page
Table 1-1. Housing Parts	1-1
Table 2-1. Connection Parts	2-1
Table 3-1. User-Interface Parts	3-3
Table 4-1. Control/Power Module Parts, for EMP 285ic 1ph	4-1
Table 4-2. Control/Power Module Parts, for EMP 285ic 3ph	4-3
Table 5-1. Wire-Feed Assembly Parts	5-5
Table 5-2. Wire-Feed Rollers: Available Sizes for Models 285ic 1ph, 3ph.....	5-5
Table 5-3. Output & Center Wire-Guide Tube: Available Sizes for Models 285ic 1ph, 3ph ...	5-6

HOUSING PARTS

SECTION 1

HOUSING PARTS

1.1 HOUSING PARTS

Table 1-1. Housing Parts

Item	Part #	Description	Qty
1	0558 102 537	Hinge	1
2	0558 102 538	Door pull & latch	1
3	0558 102 620	Side door, spool side (EMP 285ic)	1
4	0558 102 544	Side frame, spool side	1
5	0558 102 399	Handle	4
6	0558 102 545	Foot (With 2× M6x20 screw)	2
7	0558 102 546	Side frame, power side	1
8	0558 102 547	Side door, power side	1

HOUSING PARTS

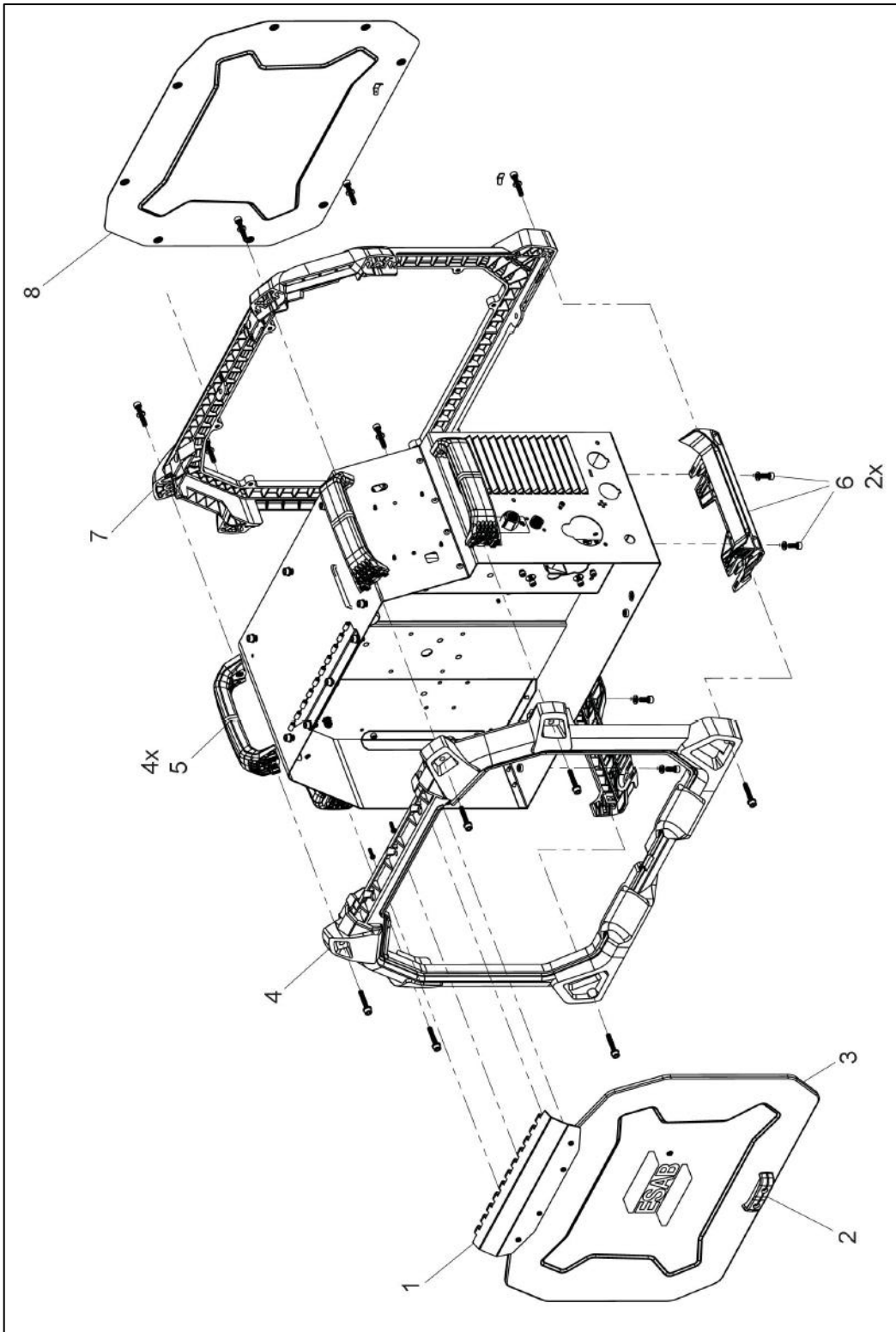

Figure 1-1. Housing

SECTION 2

CONNECTION PARTS

2.1 CONNECTION PARTS



NOTE

Except for the Power Switch (6), all Connection Parts are the same for both the 3ph and 1ph.

Table 2-1. Connection Parts

Item	Part #	Description	Qty
1	0558 102 521	Brake hub kit	1
2	0558 102 522	MIG gas solenoid system	1
3	0558 102 523	TIG/Spool gun gas solenoid system	1
4	0558 102 525	Bracket, gas solenoid mounting	1
5	0558 102 524	Gas inlet/outlet, bulkhead fitting	3
6	0558 102 615	Power switch, 1ph only	1
	0464 646 880	Power switch, 3ph only	1
7	0558 102 611	Fan Bracket assembly	1
8	0558 102 527	Female OKC connector	2
9	0558 102 593	Polarity change cable & male OKC connector	1
10	0558 102 612	Wire drive assembly, bayonet connector	1
11	0558 102 530	8 pin female remote receptacle and harness	1

USER-INTERFACE PARTS

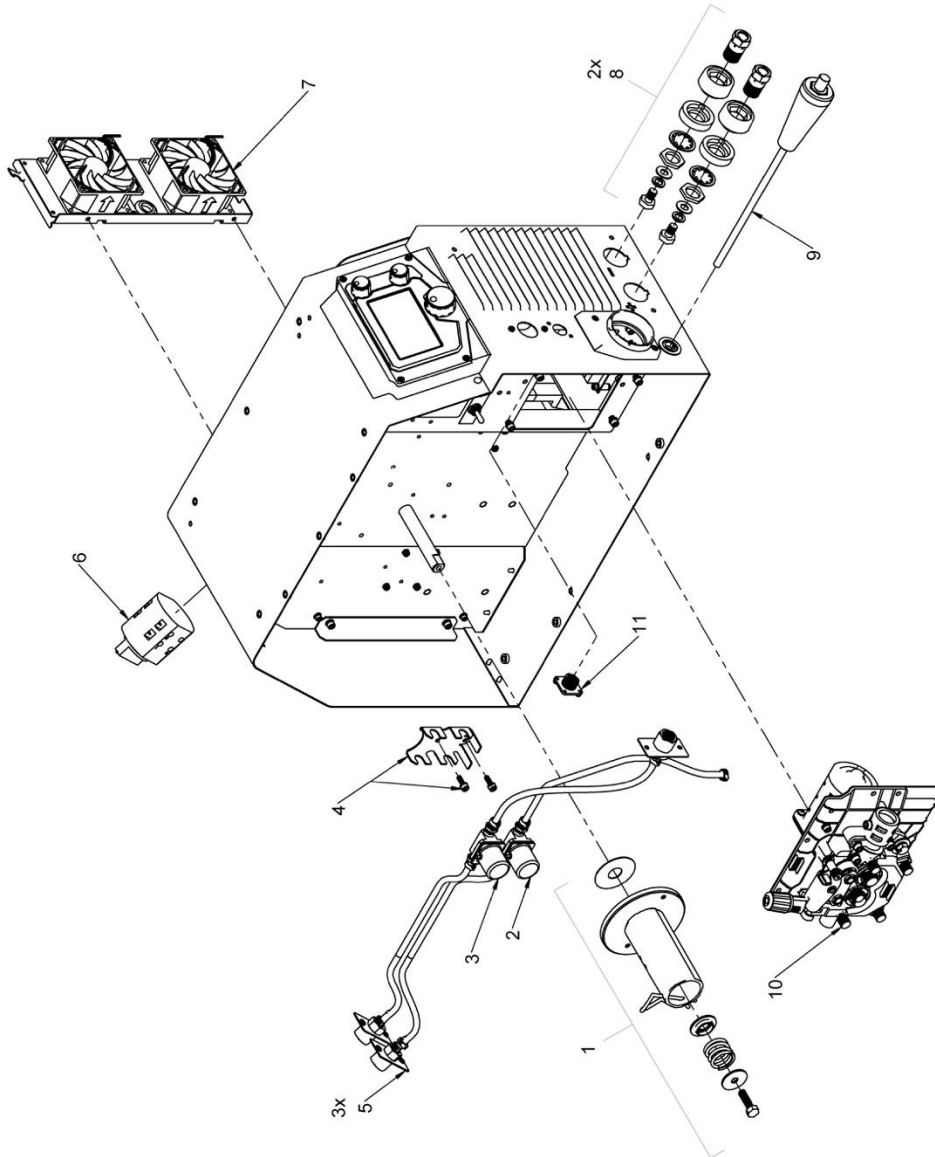

Figure 2-1. Connections

USER-INTERFACE PARTS

SECTION 3

USER-INTERFACE PARTS

3.1 USER-INTERFACE PARTS

Table 3-1. User-Interface Parts

EMP 285ic 1ph

Item	Part #	Description	Qty
1	0558 102 618	User interface complete	1
2	0558 102 438	Replaceable display lens	1
3	0558 102 423	Encoder for small knob	2
4	0558 102 424	Encoder for large knob	1
5	0558 102 440	Knob, small	2
6	0558 102 441	Knob, large	1
7	0558 102 616	Lens assembly kit	1

EMP 285ic 3ph

Item	Part #	Description	Qty
1	0558 102 619	User interface complete	1
2	0558 102 438	Replaceable display lens	1
3	0558 102 423	Encoder for small knob	2
4	0558 102 424	Encoder for large knob	1
5	0558 102 440	Knob, small	2
6	0558 102 441	Knob, large	1
7	0558 102 617	Lens assembly kit	1

USER-INTERFACE PARTS

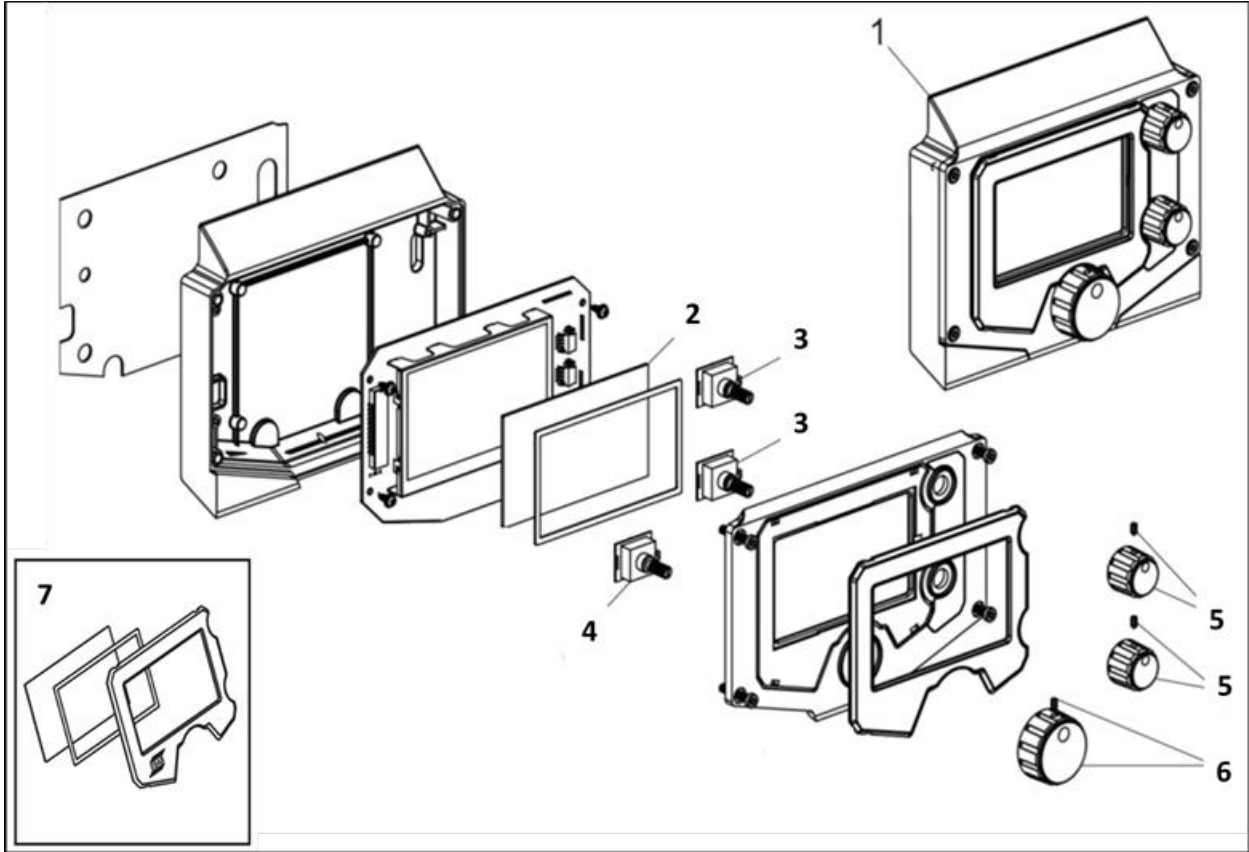

Figure 3-1. User-Interface

SECTION 4

CONTROL/POWER MODULE PARTS

4.1 CONTROL/POWER MODULE PARTS FOR EMP 285ic 1ph

Table 4-1. Control/Power Module Parts, for EMP 285ic 1ph

Item	Part #	Description	Qty
1	0558 102 427	Control PCB	1
2	0558 102 613	Main Power Board Assembly	1
3	0558 102 595	Output Inductor	1
4	0558 102 596	Output Diode Assembly	1
5	0464 625 880	Main Transformer	1
6	0558 102 431	PFC Inductor assembly	1
7	0558 102 535	Strain relief, mains cable	1
8	0558 102 614	Mains Cable	1

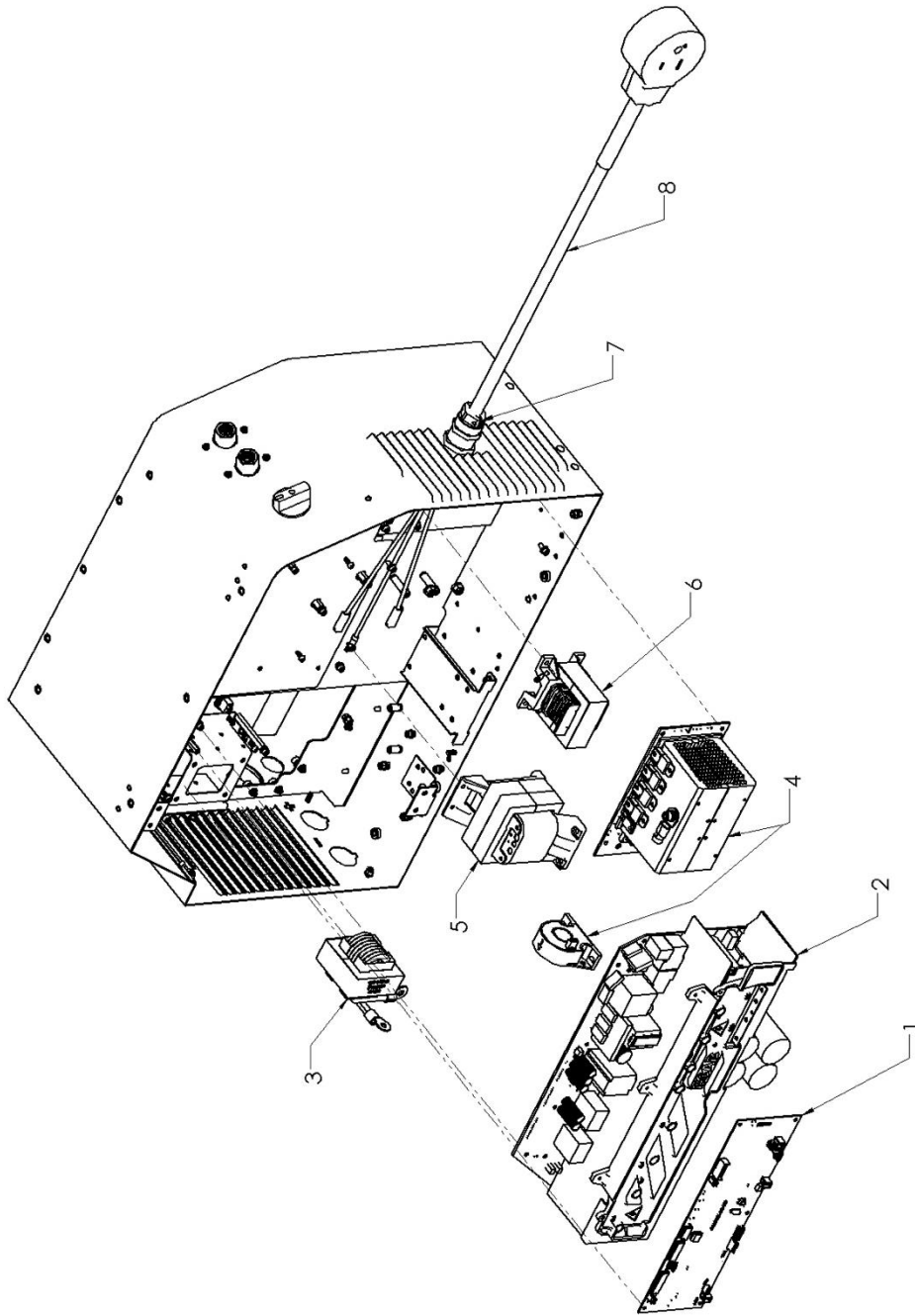

Figure 4-1. Power-Side Module Parts, EMP 285ic 1 ph

4.2 CONTROL/POWER MODULE PARTS FOR EMP 285ic 3ph

Table 4-2. Control/Power Module Parts, for EMP 285ic 3ph

Item	Part #	Description	Qty
1	0558102427	Control PCB	1
2	0558102621	Main Power Board Assembly	1
3	0558102595	Output Inductor	1
4	0558102596	Output Diode Assembly	1
5	0558102626	Main Transformer	1
6	0558102628	IPS Board Assembly	1
7	0558102535	Strain relief, mains cable	1
8	0558102622	Mains Cable	1
9	0558102624	Filter Board Assembly	1

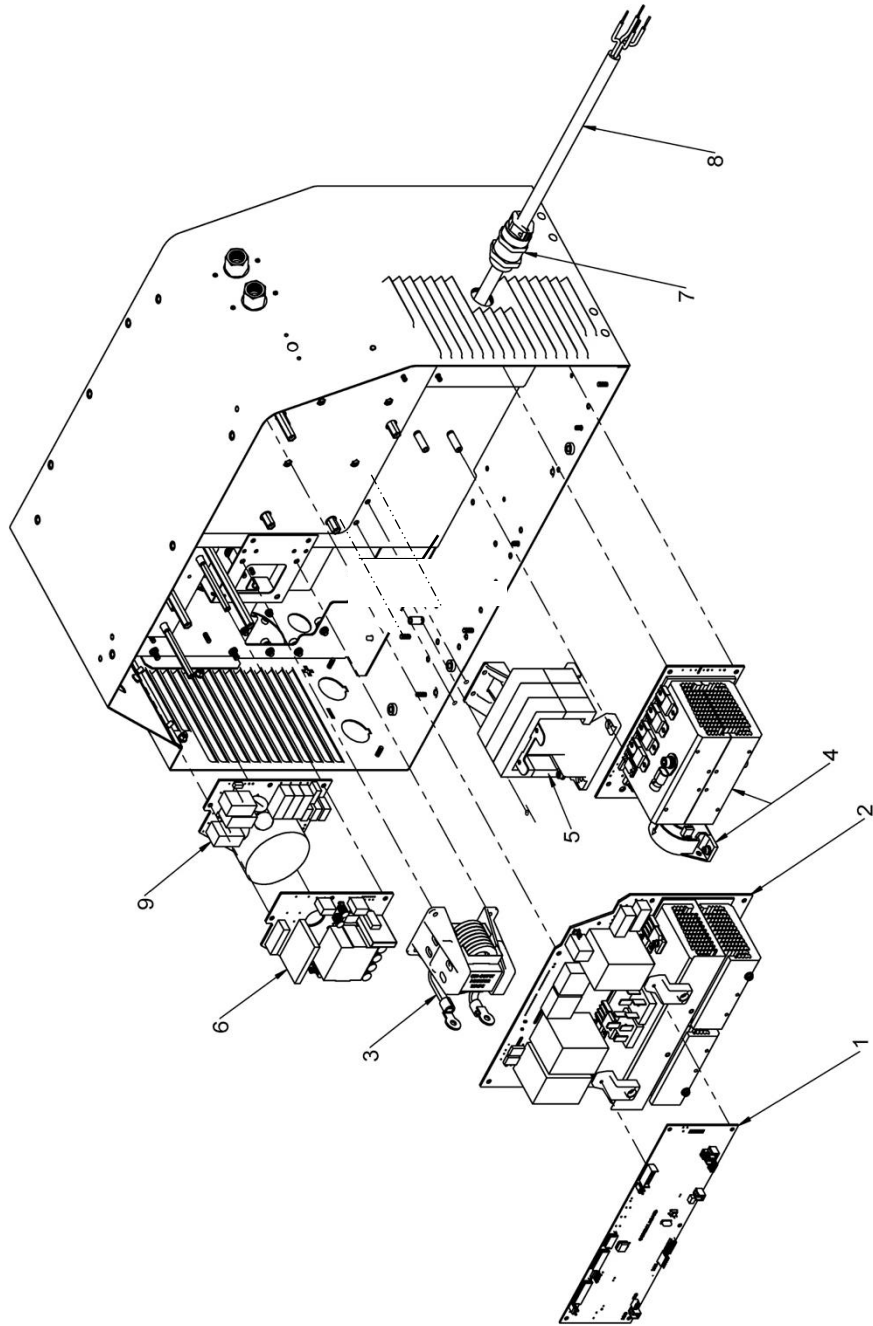

Figure 4-2. Power-Side Module Parts, EMP 285ic 3ph

SECTION 5

WIRE-FEED ASSEMBLY PARTS

5.1 WIRE-FEED ASSEMBLY PARTS



NOTE

All Wire-Feed Assembly Parts are common for both EMP 285ic 1ph & EMP 285ic 3ph

Table 5-1. Wire-Feed Assembly Parts

Item	Part #	DESCRIPTION	Qty
1	0558102591	PRESSURE ROLLER ASSEMBLY	1
2	0558102592	TENSION ADJUSTMENT ASSEMBLY	1
3	0558102608	CENTER WIRE-GUIDE TUBE	1
4	(SEE Table 5-3 BELOW)	OUTPUT WIRE-GUIDE TUBE	1
5	0558102609	MOTOR-GEAR SHAFT WOODRUFF KEY	1
6	0558102597	INLET QUAD WF	1
7	0558102605	DRIVEN GEAR ASSEMBLY	2
8	0558102606	DRIVE GEAR ASSEMBLY	1
9	(SEE Table 5-2 BELOW)	WIRE-FEED ROLLERS	2
10	0558102600	WASHER FLAT M4 LARGE OD	3
11	0558102601	THUMB SCREW M4 X 10 X 8 KNURLED	2
12	0558102602	THUMB SCREW M4 X 10 X 5 KNURLED	1
13	0558102603	QUAD WF COVER	1
14	0558102604	THUMB SCREW M5 X 14 KNURLED	5
15	0558102625	WIRE DRIVE KNOB, BAYONET	1

Table 5-2. Wire-Feed Rollers: Available Sizes for Models 285ic 1ph, 3ph

ITEM	PART #	DESCRIPTION	COMMENT
FEED ROLLERS FOR ALL WIRES EXCEPT ALUMINUM			
1	21155	ROLLER, .024 (.6) - .030 (.8), V-SOLID	OPTIONAL FOR PURCHASE
2	21156	ROLLER, .035 (0.9) - .045 (1.2), V-SOLID	DEFAULT*/ACCESSORY**
3	21157	ROLLER, .052 (1.4) - .062 (1.6), V-SOLID	OPTIONAL FOR PURCHASE
4	21160	ROLLER, .030 (0.8) - .035 (0.9), V-KNURLED	OPTIONAL FOR PURCHASE
5	21161	ROLLER, .045 (1.2) - .052 (1.4), V-KNURLED	ACCESSORY**
FEED ROLLERS FOR ALUMINUM WIRE			
6	21159	ROLLER, .045 (1.2) - .062 (1.6), ALUM (U-GROOVE)	OPTIONAL FOR PURCHASE
* DEFAULT (size included in package)			
** ACCESSORY (included with each model)			

Table 5-3. Output & Center Wire -Guide Tube: Available Sizes for Models 285ic 1ph, 3ph

ITEM #	PART #	DESCRIPTION	COMMENT
OUTPUT WIRE-GUIDE TUBES EXCEPT FOR ALUMINUM WIRE			
1	0558 102 585	TUBE, WIRE GUIDE .024 (.6), V-SOLID	OPTIONAL FOR PURCHASE
2	0558 102 584	TUBE, WIRE GUIDE .030 (.8) - .040 (1.0), V-SOLID	ACCESSORY**
3	0558 102 582	TUBE, WIRE GUIDE .035 (0.9) - .045 (1.2), V-SOLID	DEFAULT*
4	0558 102 583	TUBE, WIRE GUIDE .052 (1.4) - .062 (1.6), V-SOLID	ACCESSORY**
OUTPUT WIRE-GUIDE TUBES FOR ALUMINUM WIRE			
5	0558 102 586	TUBE, WIRE GUIDE .035 (0.9), ALUM	OPTIONAL FOR PURCHASE
6	0558 102 587	TUBE, WIRE GUIDE .045 (1.2), ALUM	OPTIONAL FOR PURCHASE
7	0558 102 588	TUBE, WIRE GUIDE .052 (1.4) - .062 (1.6), ALUM	OPTIONAL FOR PURCHASE
* DEFAULT (size included in package)			
** ACCESSORY (optional size included with each model)			

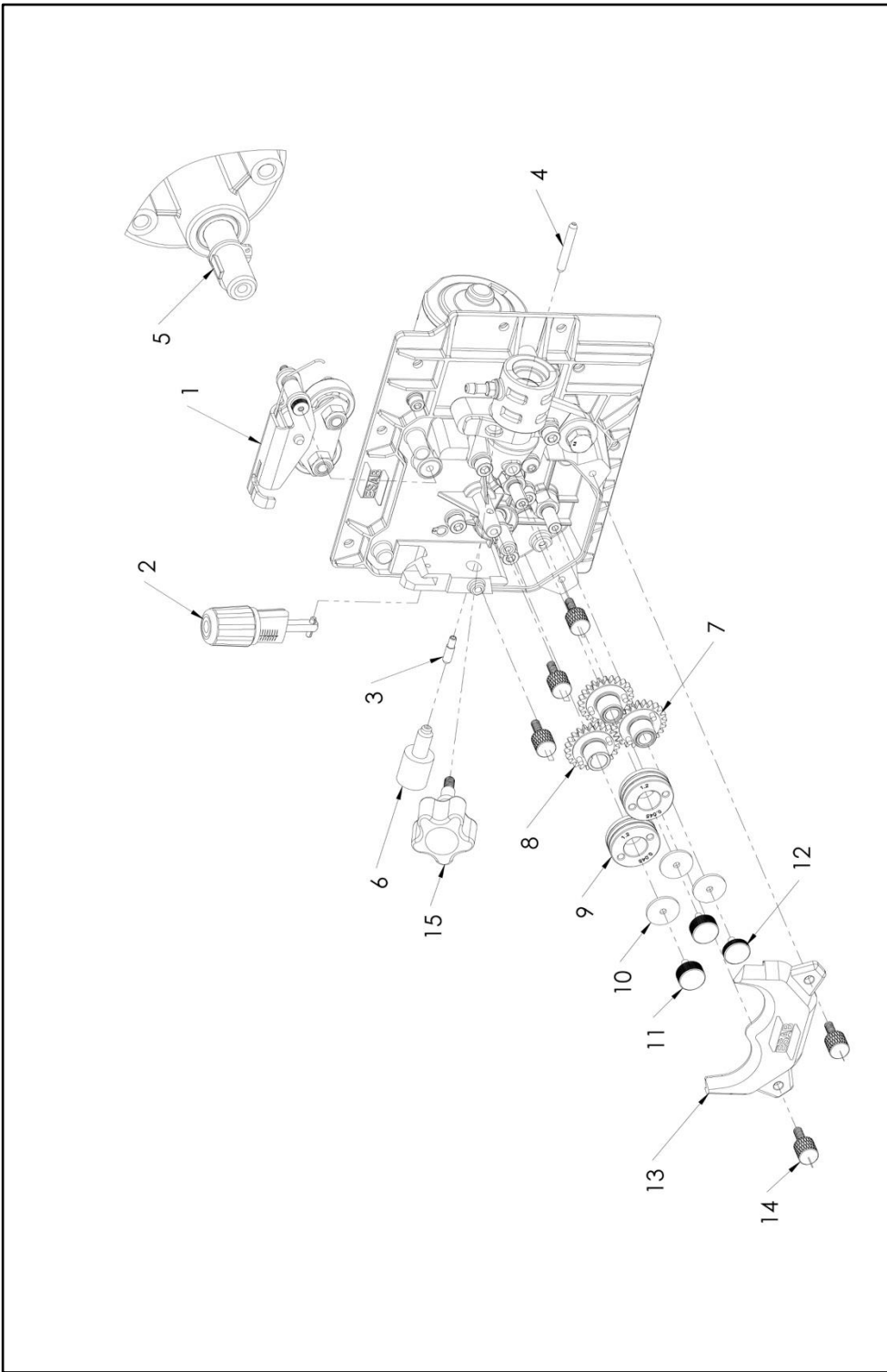

Figure 5-1. Wire-Feed Assembly

ESAB Subsidiaries and Representative Offices

AUSTRIA

ESAB Ges.m.b.H
Vienna-Liesing
Tel: +43 1 888 25 11
Fax: +43 1 888 25 11 85

BELGIUM

S.A. ESAB N.V. Heist-
op-den-Berg Tel: +32
15 25 79 30 Fax: +32
15 25 79 44

BULGARIA

ESAB Kft Representative Office
Sofia
Tel: +359 2 974 42 88
Fax: +359 2 974 42 88

THE CZECH REPUBLIC

ESAB VAMBERK s.r.o.
Vamberk
Tel: +420 2 819 40 885
Fax: +420 2 819 40 120

DENMARK

Aktieselskabet ESAB
Herlev
Tel: +45 36 30 01 11
Fax: +45 36 30 40 03

FINLAND

ESAB Oy
Helsinki
Tel: +358 9 547 761
Fax: +358 9 547 77 71

GREAT BRITAIN

ESAB Group (UK) Ltd
Waltham Cross
Tel: +44 1992 76 85 15
Fax: +44 1992 71 58 03

ESAB Automation Ltd

Andover
Tel: +44 1264 33 22 33
Fax: +44 1264 33 20 74

FRANCE

ESAB France S.A.
Cergy Pontoise
Tel: +33 1 30 75 55 00
Fax: +33 1 30 75 55 24

GERMANY

ESAB Welding & Cutting GmbH
Langenfeld
Tel: +49 2173 3945-0
Fax: +49 2173 3945-218

HUNGARY

ESAB Kft
Budapest
Tel: +36 1 20 44 182
Fax: +36 1 20 44 186

ITALY

ESAB Saldatura S.p.A. Bareggio
(Mi)
Tel: +39 02 97 96 8.1
Fax: +39 02 97 96 87 01

THE NETHERLANDS

ESAB Nederland B.V.
Amersfoort
Tel: +31 33 422 35 55
Fax: +31 33 422 35 44

NORWAY

AS ESAB
Larvik
Tel: +47 33 12 10 00
Fax: +47 33 11 52 03

POLAND

ESAB Sp.zo.o. Katowice
Tel: +48 32 351 11 00
Fax: +48 32 351 11 20

PORTUGAL

ESAB Lda
Lisbon
Tel: +351 8 310 960
Fax: +351 1 859 1277

ROMANIA

ESAB Romania Trading SRL
Bucharest
Tel: +40 316 900 600
Fax: +40 316 900 601

RUSSIA

LLC ESAB
Moscow
Tel: +7 (495) 663 20 08
Fax: +7 (495) 663 20 09

SLOVAKIA

ESAB Slovakia s.r.o. Bratislava
Tel: +421 7 44 88 24 26
Fax: +421 7 44 88 87 41

SPAIN

ESAB Ibérica S.A.
San Fernando de Henares
(MADRID)
Tel: +34 91 878 3600
Fax: +34 91 802 3461

SWEDEN

ESAB Sverige AB Gothenburg
Tel: +46 31 50 95 00
Fax: +46 31 50 92 22

ESAB International AB

Gothenburg
Tel: +46 31 50 90 00
Fax: +46 31 50 93 60

SWITZERLAND

ESAB Europe GmbH Baar
Tel: +41 1 741 25 25
Fax: +41 1 740 30 55

UKRAINE

ESAB Ukraine LLC Kiev
Tel: +38 (044) 501 23 24
Fax: +38 (044) 575 21 88
North and South America

ARGENTINA

CONARCO
Buenos Aires
Tel: +54 11 4 753 4039
Fax: +54 11 4 753 6313

BRAZIL

ESAB S.A.
Contagem-MG
Tel: +55 31 2191 4333
Fax: +55 31 2191 4440

CANADA

ESAB Group Canada Inc.
Mississauga, Ontario
Tel: +1 905 670 0220
Fax: +1 905 670 4879

MEXICO

ESAB Mexico S.A.
Monterrey
Tel: +52 8 350 5959
Fax: +52 8 350 7554

USA

ESAB Welding & Cutting
Products
Florence, SC
Tel: +1 843 669 4411
Fax: +1 843 664 5748

Asia/Pacific

AUSTRALIA

ESAB South Pacific
Archerfield BC QLD 4108
Tel: +61 1300 372 228
Fax: +61 7 3711 2328

CHINA

Shanghai ESAB A/P
Shanghai
Tel: +86 21 2326 3000
Fax: +86 21 6566 6622

INDIA

ESAB India Ltd
Calcutta
Tel: +91 33 478 45 17
Fax: +91 33 468 18 80

INDONESIA

P.T. ESABindo
Pratama Jakarta
Tel: +62 21 460 0188
Fax: +62 21 461 2929

JAPAN

ESAB Japan
Tokyo
Tel: +81 45 670 7073
Fax: +81 45 670 7001

MALAYSIA

ESAB (Malaysia) Snd Bhd
USJ
Tel: +603 8023 7835
Fax: +603 8023 0225

SINGAPORE

ESAB Asia/Pacific Pte Ltd
Singapore
Tel: +65 6861 43 22
Fax: +65 6861 31 95
SOUTH KOREA
ESAB SeAH
Corporation
Kyungnam
Tel: +82 55 269 8170
Fax: +82 55 289 8864

UNITED ARAB EMIRATES

ESAB Middle East FZE
Dubai
Tel: +971 4 887 21 11
Fax: +971 4 887 22 63

Africa

EGYPT

ESAB
Egypt
Dokki-
Cairo
Tel: +20 2 390 96 69
Fax: +20 2 393 32 13

SOUTH AFRICA

ESAB Africa Welding &
Cutting Ltd
Durbanvill 7570 - Cape
Town Tel: +27 (0)21 975
8924

Distributors

For addresses and phone
numbers to our
distributors in other
countries, please visit our
home page
www.esab.com



www.esab.com

